

Exhaust
Mobile: 1" thread
Marine: ø40 hose connection

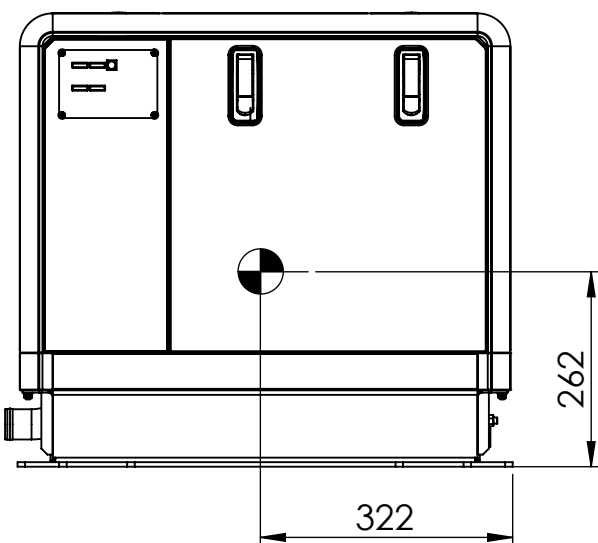

Dry weight: 154Kg

UNLESS OTHERWISE SPECIFIED: CHAMFER SHARP EDGES GENERAL TOLERANCE NEN ISO 2768-m FORM AND PLACE TOLERANCES NEN-ISO 1101 WELDING SYMBOL NEN EN 22553 ROUGHNESS ACC. to NEN3634				TOLERANCE PRINCIPLE ISO 8015		FINISH: -		DO NOT SCALE DRAWING	
				PROJECTION : THIRD ANGLE UNITS : mm		Material:		SHEET FORMAT: A3	
								TITLE: GV Genverter 2 cylinder	
DRAWN J.K.		SIGNATURE		DATE 22-4-2014		STATUS: Design		ARTICLE NO. NOT_REQUIRED	
CHK'D						DRAWING: 9600MD302		REVISION	
PRINTED				23-6-2014		Weight: 154000.00 gram		SCALE:1:7.5	
								SHEET 1 OF 1	

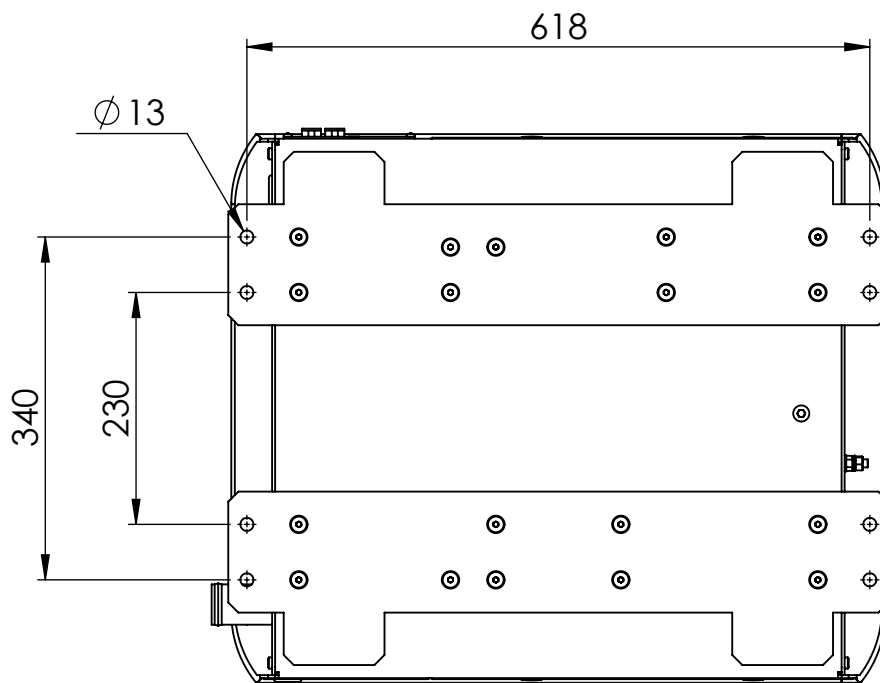
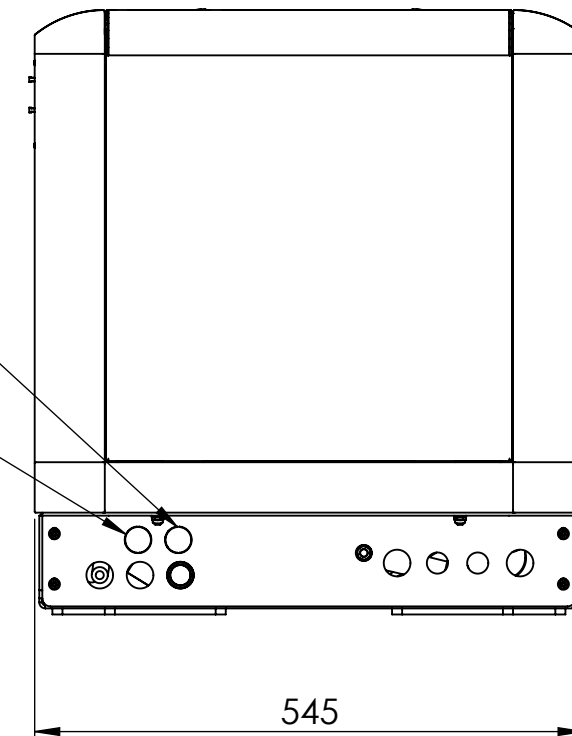
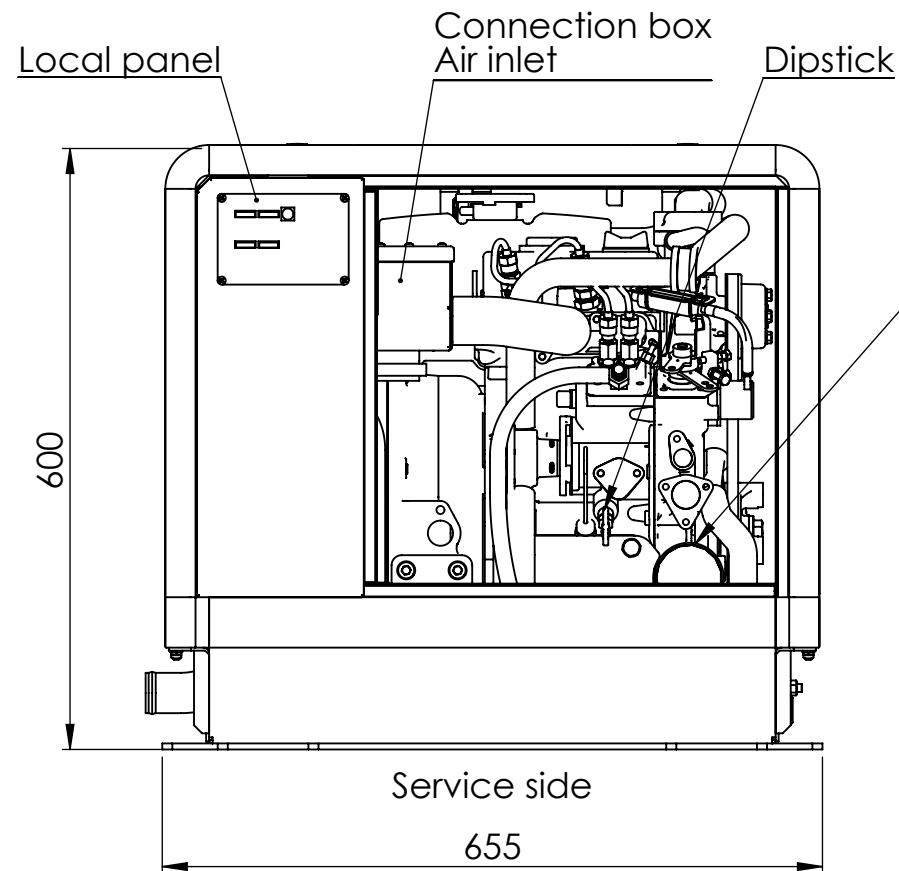