



Generating Confidence

Model: M-SQ Pro 18 Marine - Non Emission
SUPER QUITE PRO SERIES 1500 RPM GENERATOR

Phase: 1 PHASE 230 V - 3 WIRE • 3 PHASE 230/400 V - 5 WIRE

Hertz : 50 HZ

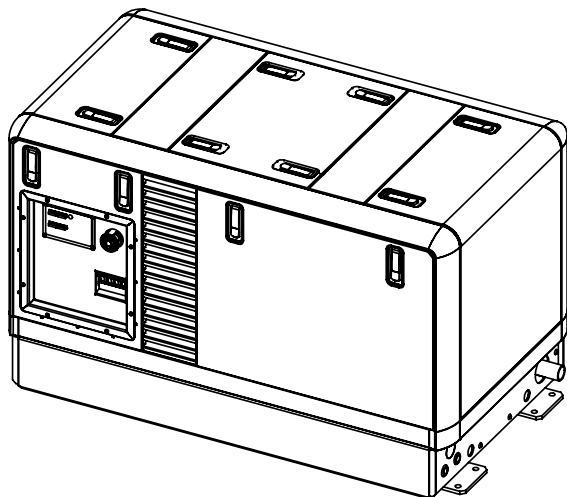

Datasheet

Engine Features

- Diesel fueled
- Rest of world no emission certified
- Four cylinder
- Four stroke
- Closed cooling system
- Marine heat exchanger and exhaust manifold
- Electric fuel lift pump
- Lifting eye
- Emergency stop optional

Generator Features

- High efficient brushless synchronous alternator
- With AVR
- Class H insulation
- Speed adjustability
- Air cooled
- Engine and generator are thermally separated from each other

Benefits

- Relaxation; Little noise from the engine and generator
- Independence: adequate energy on board, less need to head for a marina.

Generator Weights and Dimensions

	Without Sound Shield		With Sound Shield	
GENERAL SPECIFICATION				
Weight kg (lb.)				
Wet	470	(1036,2)	510	(1124,4)
Dry	455	(1003,1)	495	(1091,3)
Length mm (in.)	999	(39,3)	1220	(48)
Width mm (in.)	568	(22,4)	719	(28,3)
Height mm (in.)	681	(26,8)	754	(29,7)

Generator Power Output Specifications

POWER OUTPUT	
Nominal Power kW	16,5
Continuous power Kva at 25°C (77°C)	20,0
Continuous power kW at 25°C (77°C)	16,0

RATINGS: Marine continuous ratings per ISO 3046, ISO 8528-1, guidelines for complete ratings definitions. Availability is subject to change without notice.

WhisperPower reserves the right to change the design or specifications without notice and without any obligation or liability whatsoever. Contact your local WhisperPower distributor for availability.

Application Data 1

ENGINE	
ENGINE SPECIFICATIONS	
Type	Kubota V2203
Cylinder, quantity	4
Displacement, L (cu. In.)	2,197 (134)
Bore, mm (in.)	87 (3,4)
Stroke, mm (in.)	92,4 (3,6)
Compression ratio	22.0
Combustion system	IDI
Nominal speed, rpm	1500
Net Continuous power at rated rpm, kW (pk)	17.2 (23.1)
Governor, type	Mechanical (+-5%)
Angular operation continuous	20°
ENGINE ELECTRICAL SYSTEM	
Battery, voltage (V)	12
Battery, charging module (A)	40
Battery, minimum recommendation (Ah)	80
Starter motor (V) (kW)	12 / 1.4 kW
COOLING SYSTEM	
Capacity, L, approx..	8.1
Radiator type	Shell and Tube Countercurrent
Thermostat	Open at 76.6°C Full open at 85°C
FUEL SYSTEM	
Fuel shutoff solenoid	Electrical (ETR)
Fuel injection pump	In-Line pump
Fuel lift pump	Facet Gold Flo
LUBRICATION SYSTEM	
Oil pump type	Pressure
Oil pan capacity with filter, L (gal.)	7.6 (2.0)
OPERATION	
OPERATION REQUIREMENTS	
Engine Speed RPM	1500
Air requirements, ft ³ / min	50.62
Max, air intake restriction, kPa	2.45
Exhaust temp. At full load	***
Max. allowed exhaust pressure, kPa	10.7
FUEL CONSUMPTION G/KWH	
100% load	235
OPTIONAL: Crankcase heater, Keel cooling, Mass free	
OTHER SPECIFICATIONS	
Exhaust mobile	1 1/2" tread
Exhaust marine	ø50 hose con.
Max operating	**
Water in/out	Hose 3/4"
Battery cable	35mm ²
Connection communication	**
Internal circuit breaker	1phase 80 A 3phase 32 A

Generator Power Ratings at 25°C (77°F)						
MODEL GENERATOR (ALTERNATOR)	PH	RPM	VOLTAGE	AMPS	kVA/ kW	HZ
NPE32 L4C SAE4 SAE7,5	1	1500	240	71	21,2/17	50
Linz SLT18 MD	3	1500	440/254	32,7/56,7	18/14,4	50

HARMONIC DISTORTION < 3%	
Configuration	1phase, series winding, 3wires 3phase, series start, 5wires

Engine Features

- Low oil pressure shutdown
- High engine temperature shutdown
- High seawater temperature shutdown
- Low vibration shock mounts
- Disposable oil filter
- Oil drain plug
- Disposable water/ fuel filter

Alternator Features

- Brushless, rotating field design permits power to be obtained from stationary leads.
- Windings are vacuum impregnated with epoxy varnish for dependability and long life.
- Rotors are dynamically balanced to minimize vibration.
- Copper windings ensure minimal heat build-up.
- Insulation meets NEMA standards for class H insulation.
- Flexible connected to the engine, the generator has double sealed precision ball bearing with a precision-machined steel sleeve in the end bracket to prevent shaft misalignment and extend bearing life.

General Conditions

- Ventilated environment
- Operating temperature of -10 °C / + 40 °C
- Storage temperature of -20 °C / +70 °C
- Relative humidity in operations / storage of max 75% RH, no-condensing

Application Data 2

General Control Basic



DDC

- Full engine control
- Robust digital sensor readout
- Basic monitoring of conventional and PM technology generators
- DDC RS485 communication to Whisper Touch Panel LCD display with all important information about the output and load
- The load bar shows the real time delivered load
- Engine will stop in the event of a fault
- It is possible to have the generator start and run according to a pre-programmed schedule
- It is possible to have the generator start and stop according to a pre-programmed schedule
- Language by choice. German, English, French, Italian, Dutch and Spanish.

General Control Advanced



Deepsea

- Full engine control
- Robust digital sensor readout
- Full analogue sensor readout
- Full monitoring of conventional generators
- Easy to integrate in PLC with modbus, CAN or Ethernet
- Possibility for loadsharing and synchronization
- Optional auto start and switchover on mains failure
- Remote communications (RS232, RS485 x2, Ethernet)
- Provides secure and simple off site monitoring
- Graphical displays showing, charts, meters, power display, graphs and engine status information
- Information is displayed clearly and in a universal format for all users
- Language by choice. German, English, French, Italian, Dutch and Spanish.

DDC CONFIGURATION

M-SQ PRO 18 • 1-PHASE / 3-PHASE

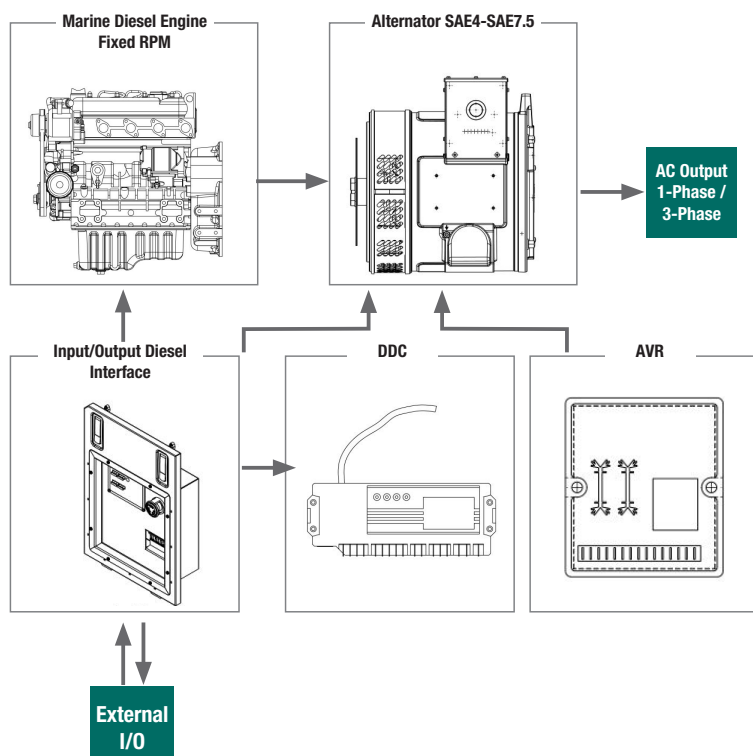

DEEPSEA CONFIGURATION

M-SQ PRO 18 • 1-PHASE / 3-PHASE

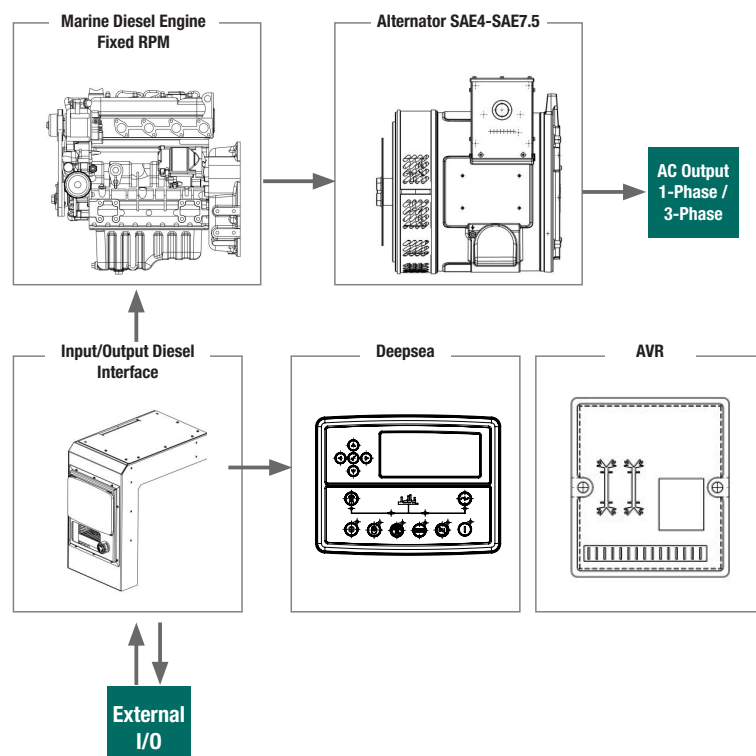

DRAWING 1 - DDC CONTROL

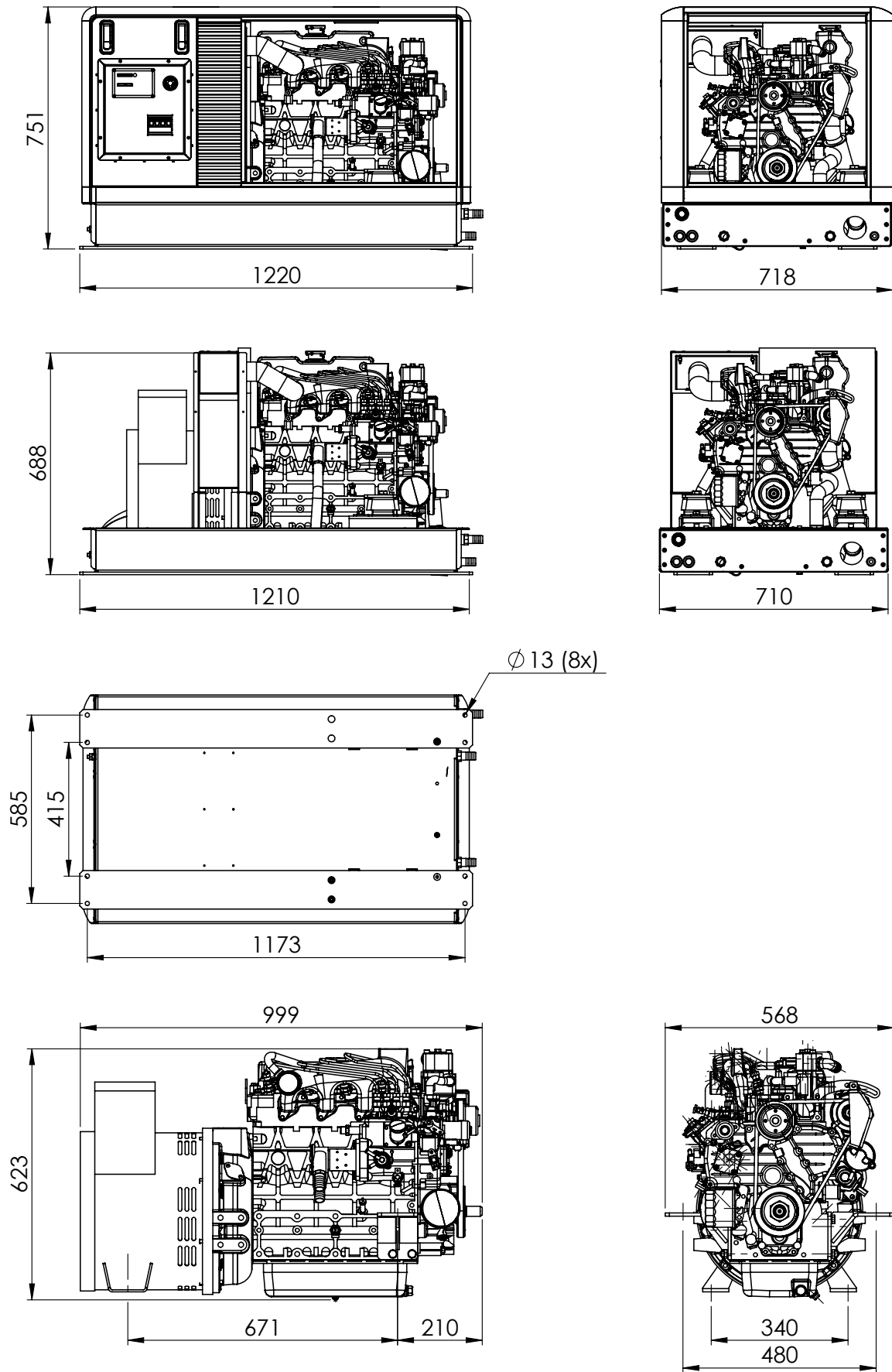

DRAWING 2 - DCC CONTROL

SQ-Pro 18

1. Battery "black" 35mm²
2. Battery "red" 35mm²
3. Air inlet
4. Earth lug M10
5. AC cable 3G 10mm² (1phase)
AC cable 4G 6mm² (2phas)
AC cable 5G 4mm² (3phase)
6. Communication cable
7. Fuelpump powercable
8. Fuses
9. Local Control Panel
10. Circuit breaker
11. Emergency stop *option
12. To Syphon hose 3/4"
13. Fuel out 8mm
14. Fuel in 8mm
15. Water in hose 3/4"
16. From Syphon hose 3/4"
17. Exhaust
18. Drain

19. Air filter
20. Oil fill
21. Accelerator
22. Waterpump
23. V-belt
24. Oil filter
25. Exhaust
26. Dynamo
27. Temperature sensor
28. Lifting eye
29. Coolant fill
30. Manifold
31. Starter motor

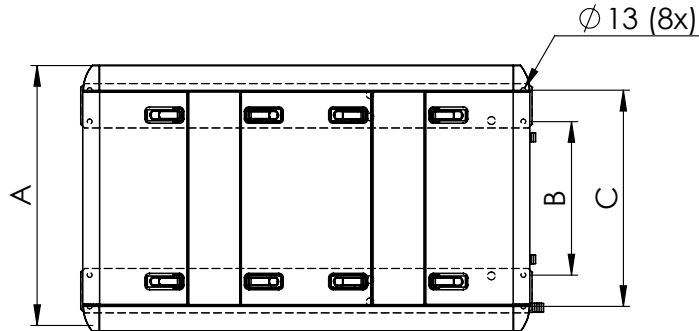

- A. 719mm
- B. 415mm
- C. 585mm
- D. 754mm
- E. 1210mm
- F. 1173mm
- G. 1220mm

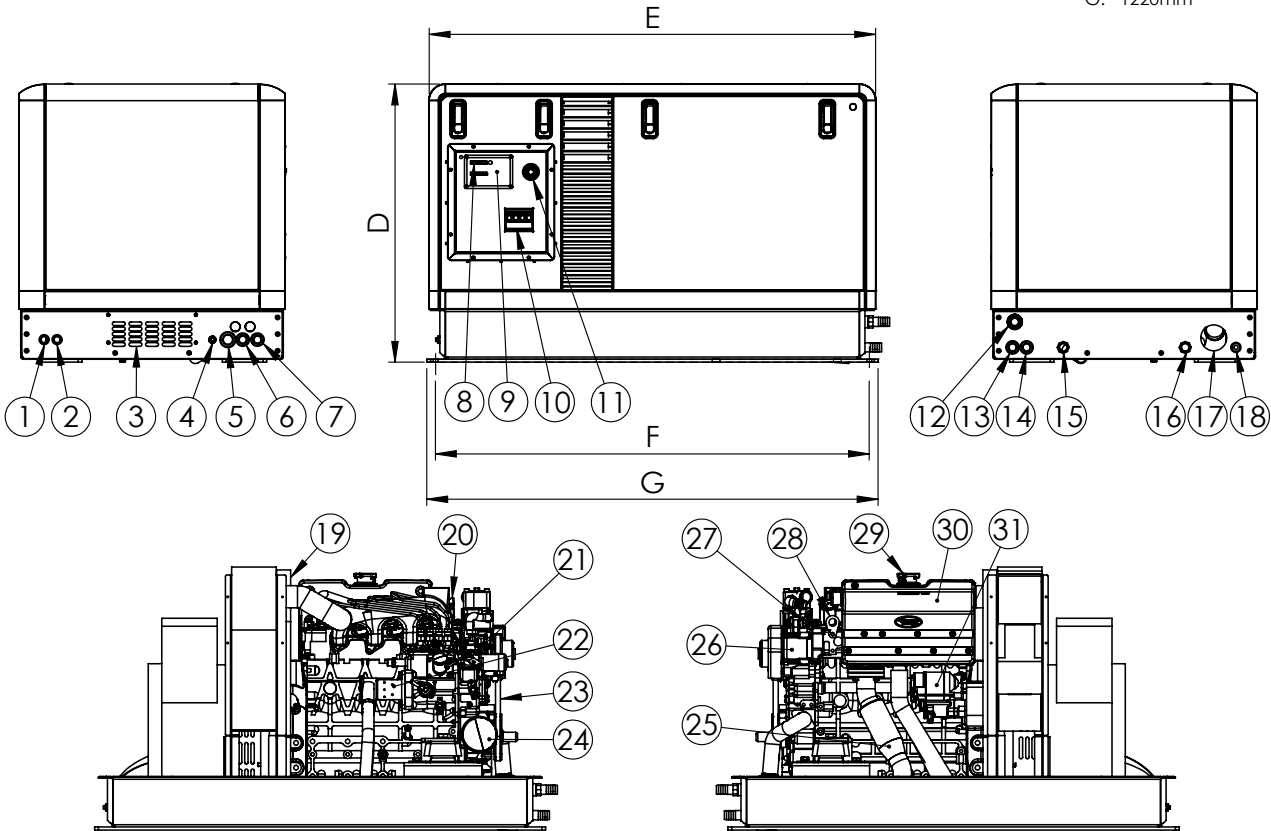

Coating
 Bottom structure Profile structure ;
 Powder Coating AE80104123621 BLACK
 Panels; Powder coating RAL9010 White
 Mass dry weight: 510kG

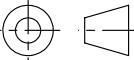
UNLESS OTHERWISE SPECIFIED: CHAMFER SHARP EDGES GENERAL TOLERANCE NEN ISO 2768-m FORM AND PLACE TOLERANCES NEN-ISO 1101 WELDING SYMBOL NEN EN 22553 ROUGHNESS ACC. to NEN3634		TOLERANCE PRINCIPLE ISO 8015		FINISH: -		DO NOT SCALE DRAWING			
PROJECTION : THIRD ANGLE UNITS : mm				Material:		SHEET FORMAT: A4			
NAME		SIGNATURE		DATE		STATUS:		TITLE: W-M-SQ-Pro 18-16 1ph Kub V2203 DDC	
DRAWN P vd V				24-3-2020		Design			
CHK'D						DRAWING:		ARTICLE NO.	
						7031A205808		REVISION	
PRINTED				17-7-2020		Weight: 0.00 gram		SCALE: 1:5	
								SHEET 1 OF 3	

DRAWING 3 - DEESEA CONTROL

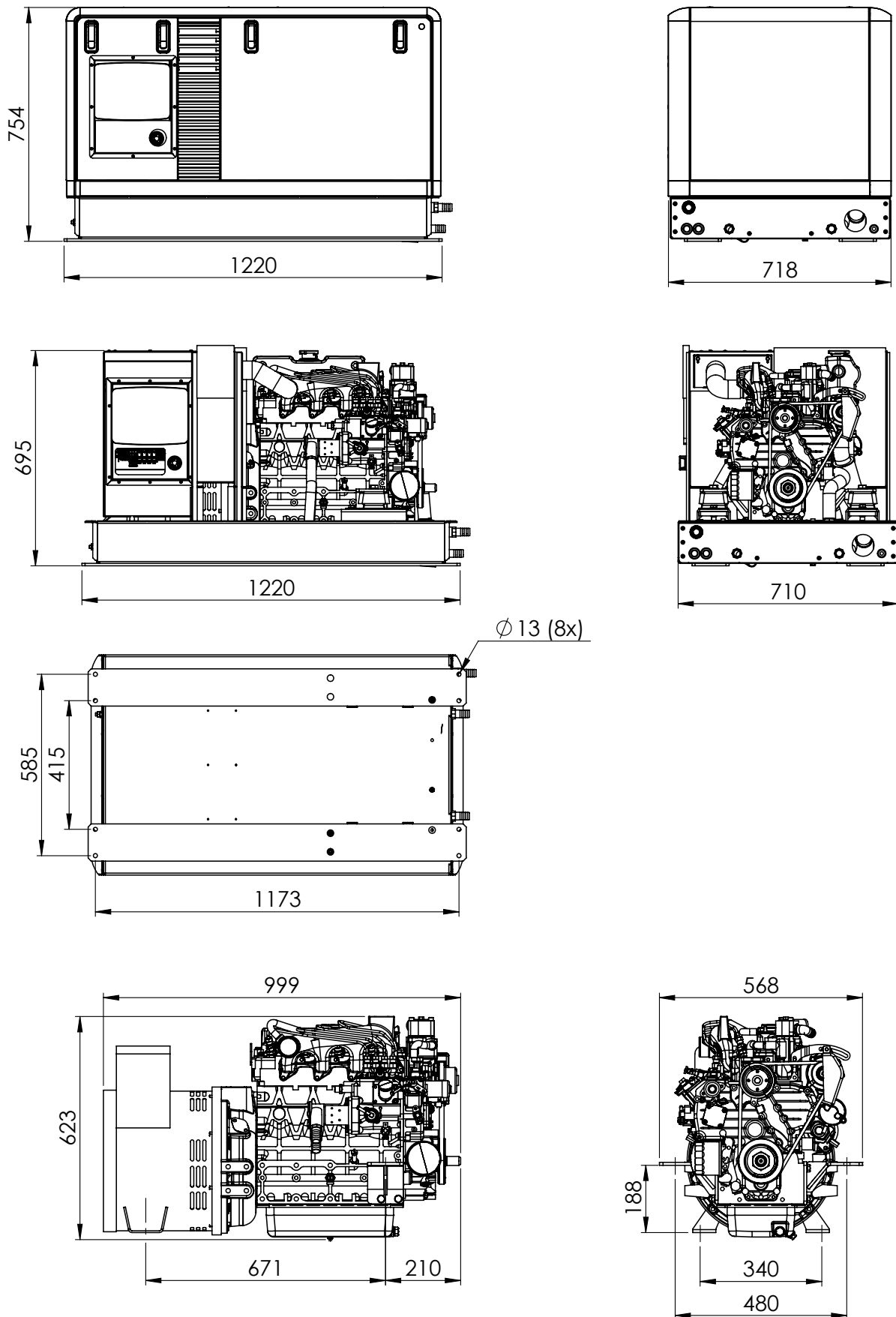

DRAWING 4 - DEESEA CONTROL

M-SQ- Pro 18

1. Battery "black" 35mm²
2. Battery "red"35mm²
3. Air inlet
4. Earth lug M10
5. AC cable 3G 10mm² (1phase)
ACcable 4G 6mm² (2phase)
AC cable 5G 4mm² (3phase)
6. Communication cable
7. Fuelpump powercable
8. Generator Control Panel
9. Fuses
10. Emergency stop *option
11. To Syphon hose 3/4"
12. Fuel out 8mm
13. Fuel in 8mm
14. Water in hose 3/4"
15. From Syphon hose 3/4"
16. Exhaust
Marine: Ø50 hose con.
17. Drain

18. Air filter
19. Oil fill
20. Accelerator
21. Waterpump
22. V-belt
23. Oil filter
24. Exhaust
25. Dynamo
26. Temperature sensor
27. Lifting eye
28. Coolant fill
29. Manifold
30. Starter motor

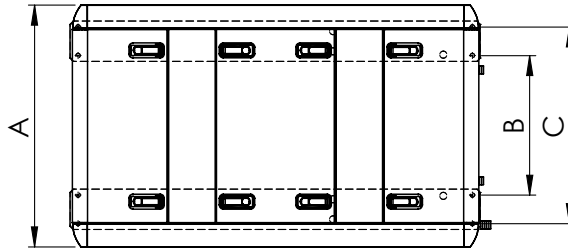

- A. 719 mm
- B. 415 mm
- C. 585 mm
- D. 754 mm
- E. 1210 mm
- F. 1173 mm
- G. 1220 mm

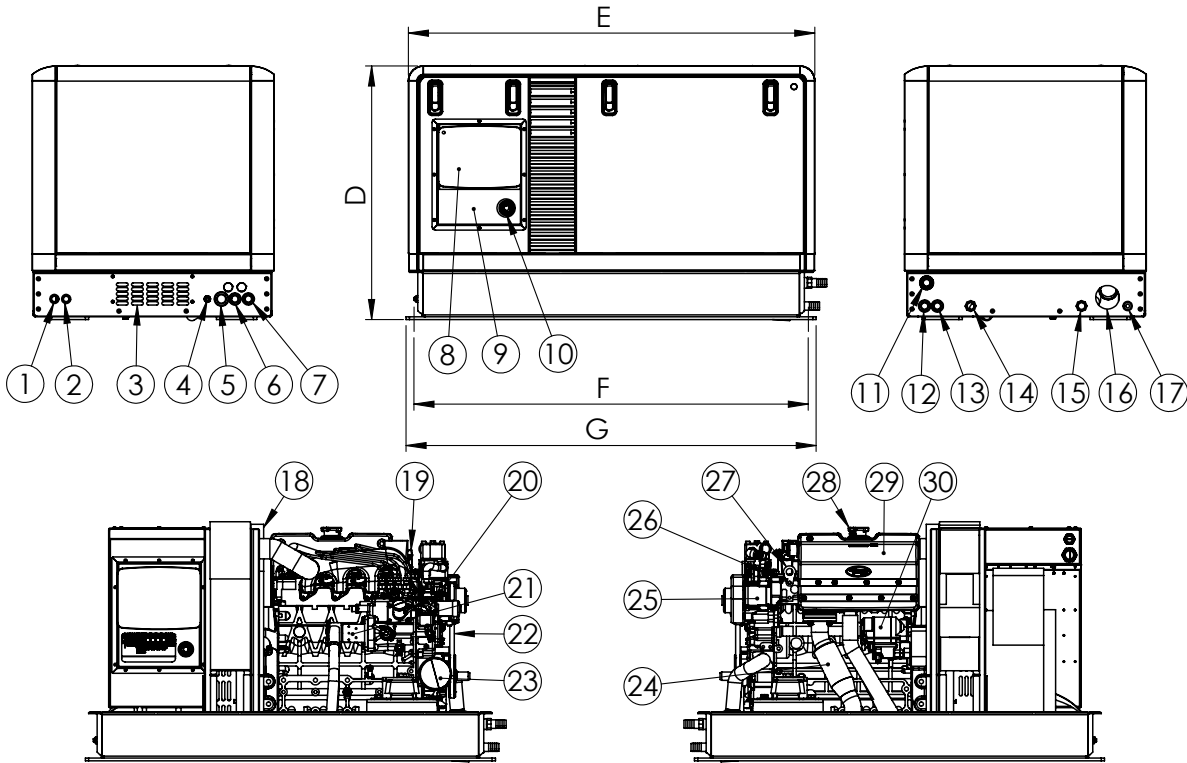

Coating
 Bottom structure Profile structure ;
 Powder Coating AE80104123621 BLACK
 Panels; Powder coating RAL9010 White
 Mass Dry Weight: 510 kG

UNLESS OTHERWISE SPECIFIED: CHAMFER SHARP EDGES GENERAL TOLERANCE NEN ISO 2768-m FORM AND PLACE TOLERANCES NEN-ISO 1101 WELDING SYMBOL NEN EN 22553 ROUGHNESS ACC. to NEN3634		TOLERANCE PRINCIPLE ISO 8015 PROJECTION : THIRD ANGLE UNITS : mm 		FINISH: - Material:		DO NOT SCALE DRAWING			
DRAWN S.K.		DATE 31-10-2018		STATUS: Design		SHEET FORMAT: A4			
CHKD				DRAWING: 7031A184738		ARTICLE NO.		REVISION	
PRINTED		DATE 12-5-2020		Weight: 294841.05 gram		SCALE:1:18		SHEET 1 OF 3	